



Highly Reliable Retrofit Exhaust Gas Sensors for older frame 5, 6, 7 & 9



When the sensor fails, only the sensor portion needs to be changed

If you have an older GE Frame turbine we are offering improved replacement exhaust gas thermocouple sensors that fit older radiation shields with base GE P/N's 351A3711, 238A7864, 219B6376, or 205B3060. This upgrade kit provides a longer lasting sensor that also features lower maintenance time at change out. There is no need to replace the existing radiation shields when using this upgraded exhaust gas sensor.

Product Features and Benefits

- Superior quality
- Hermetically sealed for high accuracy and long life
- Simple quick installation saves time
- Talented technical support

Install a sensor that has a separate cable and thermocouple...

...instead of replacing thermocouples that are routed like this

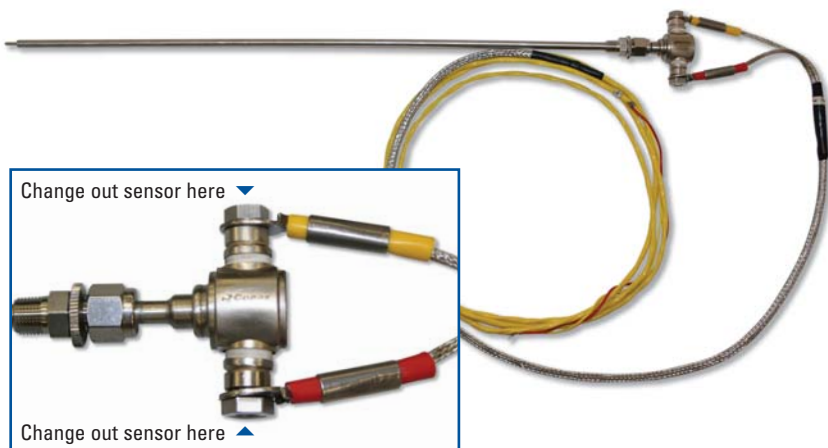

Cable assemblies that are purchased with this sensor may be manufactured to the customer desired length. Cables remain fixed in the Turbine hot box and only the sensor needs to be removed. Cable assemblies are made from 18 Awg stranded conductors with PFA insulation and are jacketed with Stainless Steel overbraid.

Technical Sales Support

Whether you are upgrading or replacing your exhaust thermocouples, Conax Technologies' Technical Team can help you solve your problems. We can help you upgrade from using the one piece design such as the 302A4010Pxxx or 351A3488Pxxx or if you just need to replace a 362A1102 exhaust gas thermocouple.

Call our inside Sales Team at (716) 684-4501 ext. 291 and you'll get the support you need to make the right choices.

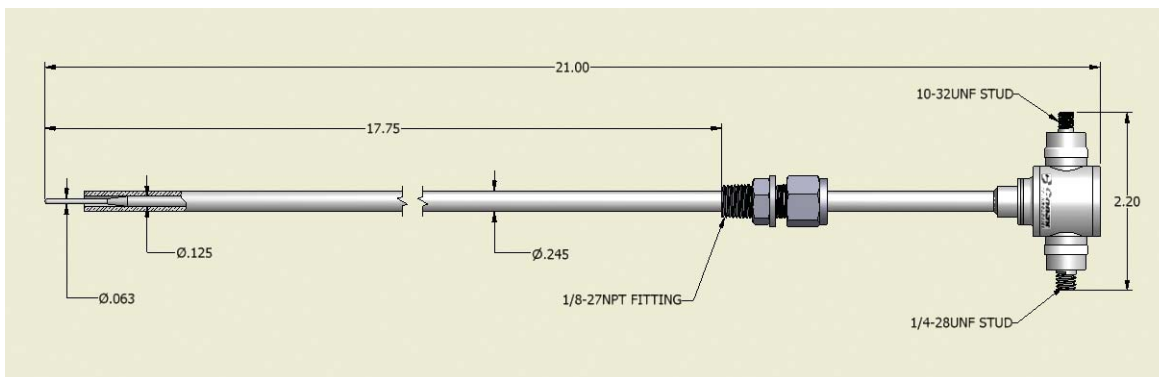

Specifications

Calibration

- Type K, Chromel Alumel®
- ± 0.4% accuracy (special limits of error)
- Meets the requirements of ASTM E585 and ASTM E608

Insulation Resistance:

- 1×10^9 ohms @ 50 VDC

Time Response:

- 2.9 seconds

Hermetic Seal:

- 1×10^{-6} ssc/sec He for the entire thermocouple

Sheath Diameter:

- 0.125" with a 0.245 Diameter oversheath

Environmental Ranges:

- -20° to 700°F (-29° to 371°C) at the termination
- -20° to 392°F (-29° to 200°C) for the cable
- 100% humidity for the entire thermocouple

Applications:

- Frame turbines

Related Products

- Exhaust Gas Thermocouple – Model 362A1102
Bulletin 6054
- Hermetic Exhaust Gas Thermocouple – Model 351A3488
Bulletin 6052
- Hermetic Wheelspace Thermocouples – Model 361A2289
Bulletin 6053
- Bearing Sensors: Bulletin 6035
- Bearing Sensor Wire Seals: Catalog 5001C
- RTDs/Thermocouples: Catalog 5005

Also Available from Conax Buffalo Technologies

- Radiation shields – Model 362A1344Pxxx; 351A3711 & others
- Mating cables – Model 361A2327Pxxx

For more information about
Conax Technologies,
visit our website:

www.conaxtechnologies.com



2300 Walden Avenue
Buffalo, New York 14225, USA
Fax: 716-684-7433 • Phone: 716-684-4500
Toll free in the USA at 1-800-223-2389
E-mail: power@conaxtechnologies.com
Website: www.conaxtechnologies.com

